



Kilia

....NEW GENERATION®

**Breaker KB 4000 and 8000**

**“THE BEST SERIES”**

“The BEST Series” is the further developed intelligent technology of Meat Machines in an outstanding hygienic design to increase both the quality and ease of use of a Breaker.

With the background of more than 85 years of experience, in developing and manufacturing food machines, **“THE BEST SERIES”** offers a world leading performance.



■  
■  
■  
■  
■  
■  
■  
■  
■  
KILIA





## The most durable Breaker!

With its standard 6 of 70 teeth the Breaker do not cut the meat across the fibres, but gently break approx mm. double fist sized pieces according to the fibres.

Thus, a very high percentage of too small pieces is avoided. Besides, the spare part costs required during the time of machine operation is kept to an absolute minimum, as the teeth do not need replacement. It has been proven that they last “forever“

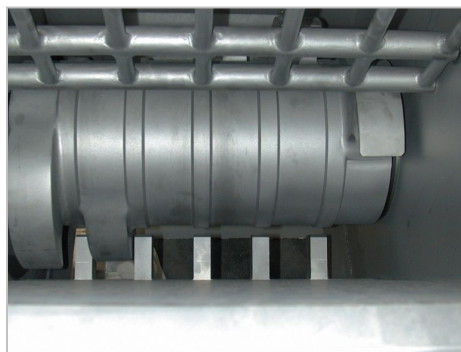



Due to a 2- fold safety interlock for unloading the machine can operate only if a standard trolley is correctly shifted into the machine body.

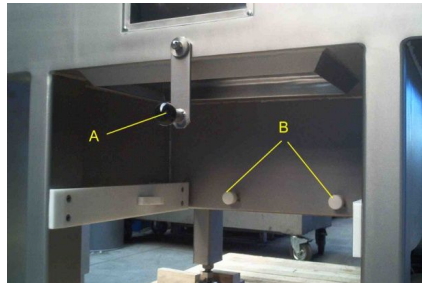

Thus it is prevented that meat falls on the floor. A plexiglass hatch enables the monitoring during production.

Via a pressure spring supported loading device the frozen meat ( block form or irregular shape, everything is possible) is transported to the breaking shaft, where it is broken into fist sized pieces.

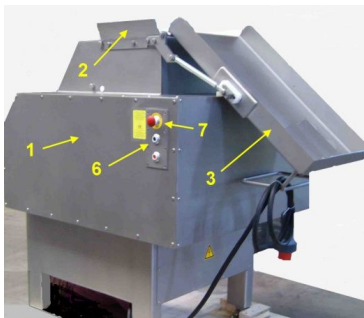

Additionally to its “ready to use equipment” various options can be added:

- Alternatively for different applications the **quantity of teeth** could be either 10 with 40 mm or 12 with 30 mm or 14 with 20 mm.

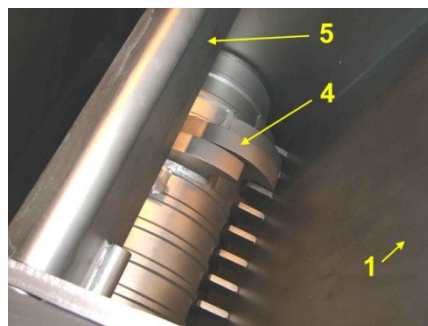

- The special version “**strong line**” is designed for products with high percentage of tendons (KB 4000 with motor of 22 Kw)





- With a **variable speed** combine with a more powerful drive the **KB 8000** can reach a capacity of up to 8 t/h.
- An **Automatic Central Lubrication System** increases the operational safety, as every single lubrication point is regularly supplied with sufficient grease.
- Alternative to the manual loader the machine could be equipped with a special designed **belt** for frozen meat blocks.



**KILIA**

## *Machine Dimensions appr. in mm:*

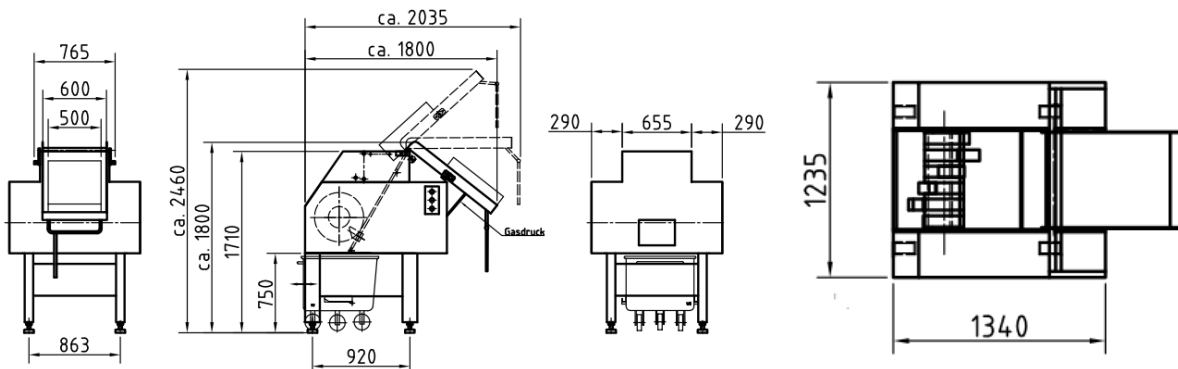



## *Technical Data:*

<b>Breaker KB “The Best Series”</b>	<b>KB 4000 / KB 8000</b>
Filling quantity appr. KG per block	50
Capacity frozen meat down to - 30 C appr. KG / H	up to 4.000 / 8.000
speed	1 / variable
KW	18,5 (22) / 30
Ampere	37 / 50
Fuse rating, A	50 / 63
Weight, kg	2500

Edition: September 2018

