



Kilia

...NEW GENERATION® Fine Mix 1200 OT

“THE CLASSICAL SERIES“

“THE CLASSICAL” Series of Food Machines fulfil the requirements of most of the customers worldwide. The classical design and the very competitive equipment components are topped by an excellent cost performance ratio.

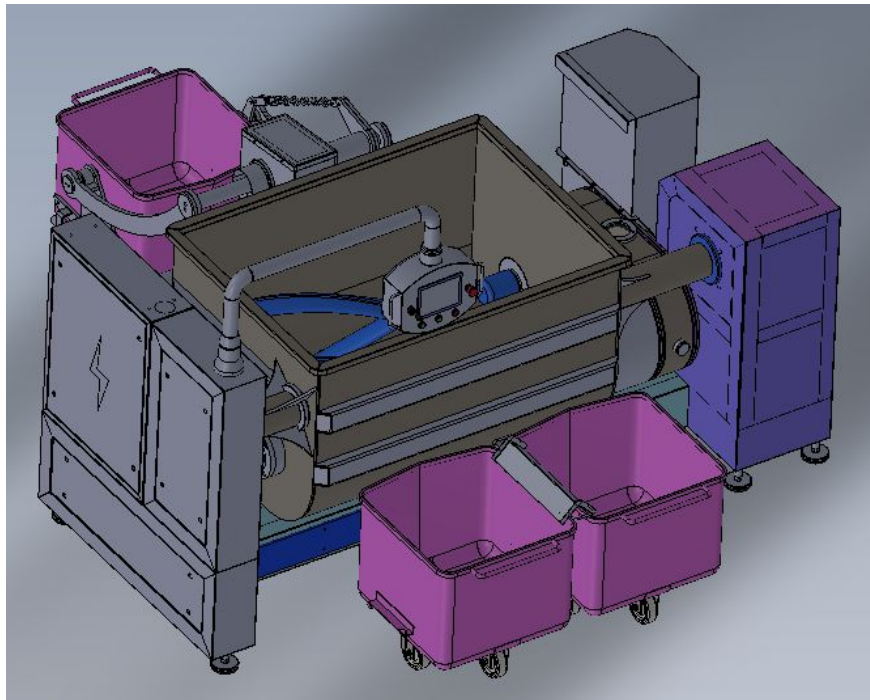

1200 Ltr. Mixer Over the Top

**Machine stainless steel**

Robust construction with a long durability machine surface and with all parts with product contact in stainless steel.



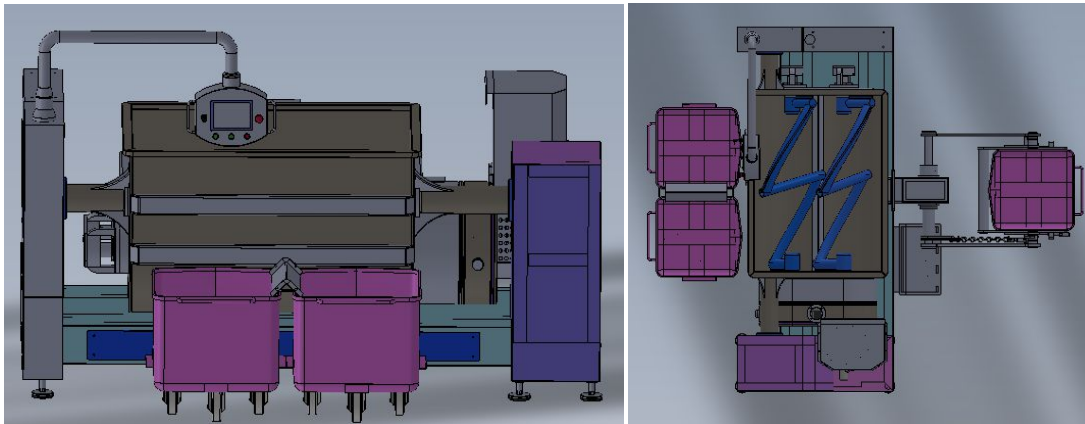

1200 Ltr. Mixer Over the Top

**Discharge over the top**

The hopper can be turned over the top for an easy discharge into the trolleys.



**Hopper approx. 1200 litres**

The stainless steel hopper easy to clean even under highest hygiene standards. The mixing capacity lies at approx. 900 batch.





## Different versions of mixing arms



Paddle



Spiral



Combination



Paddle Arms

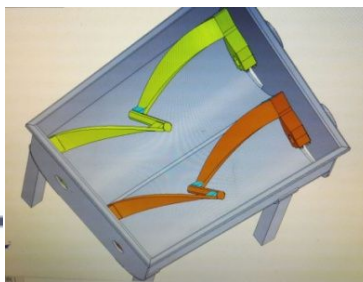

Z-Arms

Depending on the product the machine could be equipped with an optimal mixing system.

## Variable mixing speed

Operated by Siemens Touch screen the mixing process can be controlled by a variable speed (15-50rpm) as well as the mixing direction (forward or backward).

## Integrated switch cabinet external Panel

The switch cabinet is fixed either at the side of the machine body or stands separately at the side.

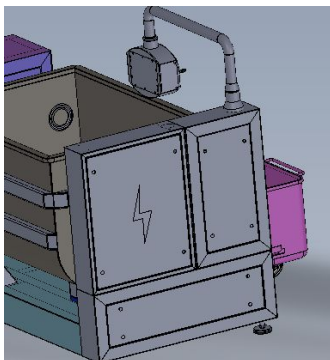



## Lift for 200 lt. Trolleys

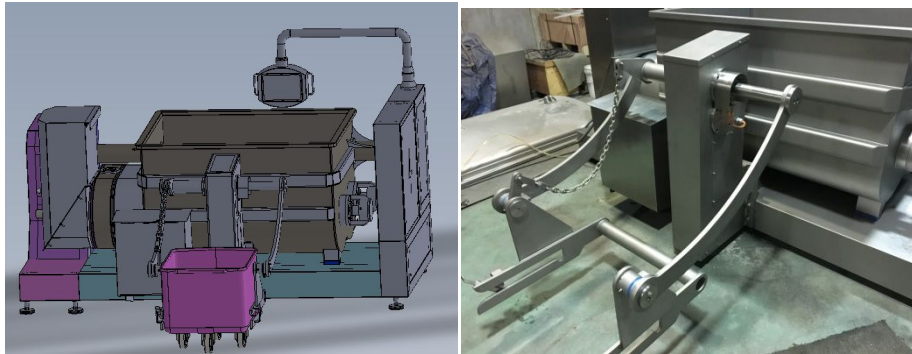

The mixer can be equipped with an integrated loader for a standard size of 200 ltr charging trolleys

### *Technical Data:*

<b>Fine Mix OT “The Classical Series”</b>	<b>1200 litres</b>
Mixing Capacity appr. In Kg/ Batch	900
Dimensions in mm (length/ width/ height)	2400x2000x1700
motor capacity kW	15
Weight, kg	1800

Edition: April 2018

