



Kilia

....NEW GENERATION®

BAND SAW

KBS 300 and KBR 300

“THE CLASSICAL” SERIES

“THE CLASSICAL” Series of Food Machines fulfil the requirements of most of the customers worldwide. The classical design and the very competitive equipment components are topped by an excellent cost performance ratio.

The Band Saws are available in two different models



Band Saw KBS 300

■
■
■
■
■
■
■
■
KILIA





Machine Dimensions appr. in mm

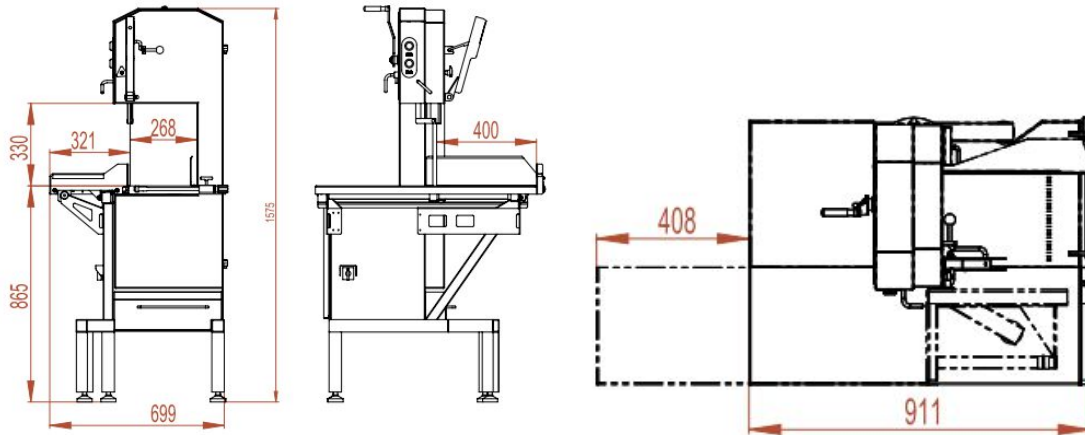

Main Technical Data:

Band Saw "The Classical Series"	KBS 300	KBR 300
Total power in kw	2,2	2,2
Voltage	400	400
Frequency	50 Hz	50 Hz
Saw belt speed	1490 rpm	1490 rpm
Weight in kg	180	245
Size working table	900× 590 mm	940× 525 x 230 mm
External Dimension	910× 700× 1575 mm	1400× 830× 1700 mm

Edition: April 2018

