



Kilia

...NEW GENERATION® **Double Clipper KDC 12/15/18**  
**“THE CLASSICAL SERIES”**

“THE CLASSICAL” Series of Food Machines fulfil the requirements of most of the customers worldwide. The classical design and the very competitive equipment components are topped by an excellent cost performance ratio.



KILIA



The **KDC 12/15/18** can be used by in the meat processing industry, in other food industries as well as in the non-food area for a wide variety of products.



### **Machine stainless steel full casing**

All machine parts with product contact are made of Stainless Steel, and the robust design ensures also excellent durability of the Machine surface.

### **Double clip procedure**

In addition to the Single clip procedure, in which only one Clip is set during the clip process, the **KDC 12/15/18** performs a double clip procedure. That means the double Clipper sets two closures simultaneously, i.e. the end of the filled packaging unit and the beginning of the next, unfilled packaging unit are closed at the same time. In the process, a knife between the two Clips cuts through the intestine (shell) while the next unit will be filled.



Clip System

Alternatively the machine can work also with loops



Loops

The **KDC 12/15/18** matches with different type of clips:



Great Wall aluminum

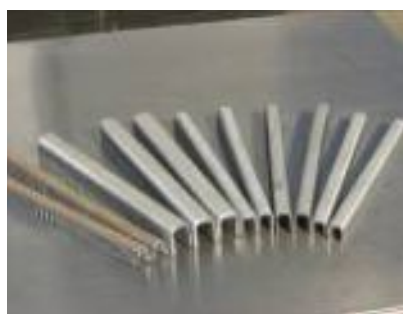

U-Mode aluminum



Aluminum wire





## Automatic processing

With its pneumatic system any kind of pneumatic clipping machine or automatic production line can be fixed for an automatic processing. An optional available twister can be easily fixed as well.



## Most modern control panel

The most modern Siemens Panel / PLC generation guarantees an easy operation as well as the highest quality standard.

## Integrated switch cabinet

All electrical and electronic components are integrated inside the machine. Therefore, no additional space is needed for another switchboard. Most of the electrical components are from the German Brand Siemens.

## Technical Data:

Double Clipper KDC “The Classical Series”	12	15	18
Clips	12	15	18
Casing Semi diameter in mm	25-60	40-120	40-200
Rate of Clipping per minute	60-150	50-100	30-100
Speed	160	100	100
Expansion mm	24-50	44-100	44-100
Cutting Pressure in Mpa	0,5-0,6	0,5-0,6	0,5-0,6
Dimensions in mm (length/ width/ height)	900x750x1800	1195x900x1900	1195x900x1900





Power in KW	3,5	3,5	3,5
Voltage	380 / 50HZ	380 / 50HZ	380 / 50HZ
Weight, kg	450	500	500

*Dimensions:*

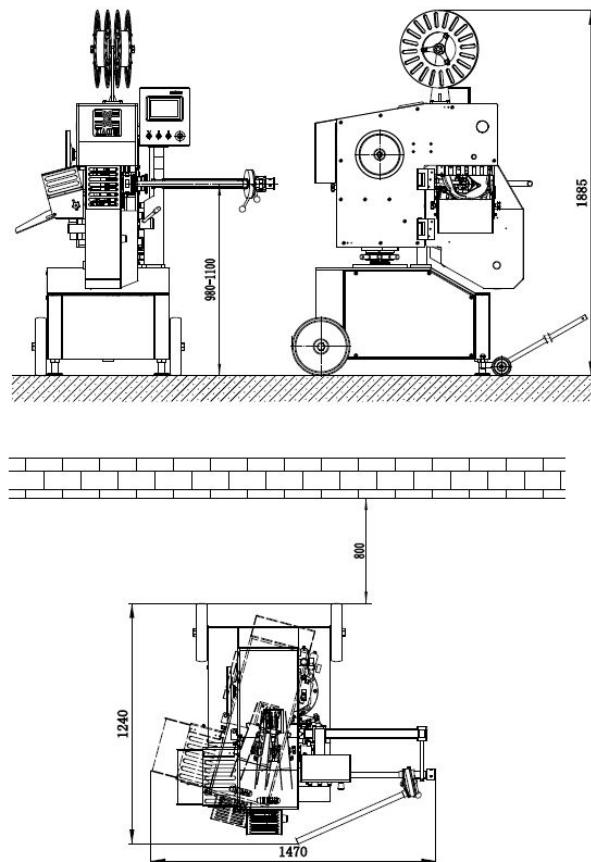

Edition: April 2019

